

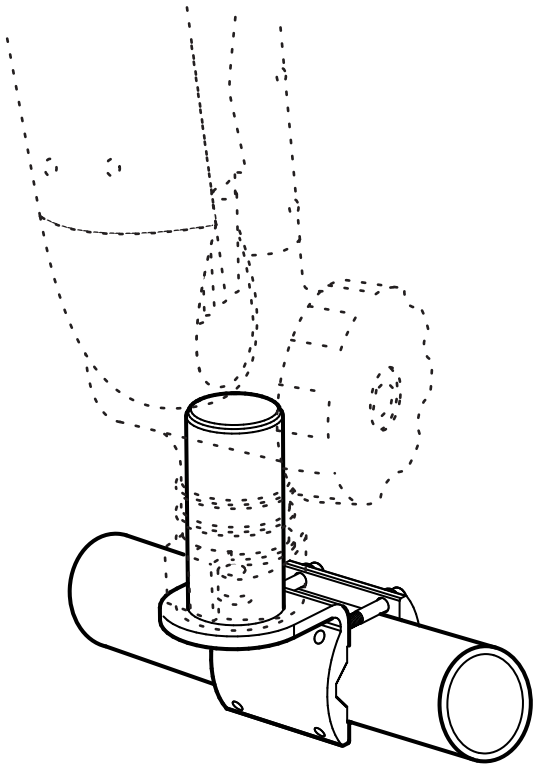

Mantis Rail Mount

Part No. MBSRR006



Common uses for this mount:

- Round Rails with .75-1.67 inch diameter (Horizontal)
- Round Rails with .5-1.67 inch diameter (Vertical)
- Square Rails .75-1.5 inch diameter (Horizontal)
- Square Rails .5-1.67 inch diameter (Vertical)

Dimensions:

- 6.2" L x 2.75" W x 3.1" H (Height of screw plate)

Contents:

- 1 Rail Mount with hardware
- (powder-coated aluminum)

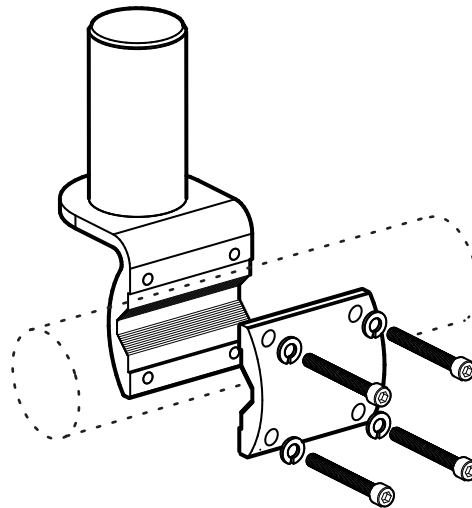

1. SELECT RAIL LOCATION

Choose a railing that will provide a sturdy mounting base for Mantis immediately behind the desired seating/standing area.

2. INSTALL BRACKET

Wrap the provided thin plastic sheet around rail. Cut to size as desired. With a 5/32 allen wrench unscrew the screws and align mount parts to rail and start each screw. Tighten all 4 cap screws securely being sure to use the supplied lock washers. **Note:** For vertical rail applications rotate the smaller mount part 90 degrees before inserting and tightening screws.

3. INSTALL MANTIS

Now place the Mantis assembly onto the vertical post of the bracket, and lock in place. *Refer to the manual supplied with Mantis for detailed instructions.*